

ALUMINCO[®]
ALUMINIUM BUILDING SYSTEMS



CLASSIC
LINE 

Classic railings with modern aesthetics
Barandillas clásicas de estética moderna

WE ARE A PART OF TOMORROW

Dirigido a la comunidad internacional de arquitectos, diseñadores, ingenieros y constructores, ofrece una amplia gama de soluciones arquitectónicas de aluminio innovadoras, energéticamente eficientes y sostenibles, que incorporan la máxima calidad, alta funcionalidad y estándares de diseño moderno. En ALUMINCO contamos con las certificaciones ISO 9001 e ISO 14001, QUALICOAT SEASIDE CLASS, mientras que todas nuestras líneas de productos están certificadas por International Foundations por sus excepcionales características y desempeño.

Targeting the international community of architects, designers, engineers, construction experts and fabricators, ALUMINCO offers a complete range of architectural aluminium solutions that are innovative, energy efficient and sustainable, embodying top quality, high functionality and contemporary design standards. ALUMINCO is an ISO 9001 and ISO 14001 certified company, QUALICOAT SEASIDE CLASS accredited, while all our product lines are certified by International Institutions for their outstanding characteristics and performances.



En Aluminco un aspecto se destaca sobre todos los demás, asumiendo la responsabilidad bajo el título "Un planeta para amar" estamos trabajando con el tema de la sostenibilidad a lo largo de toda la cadena de valor, con lo que contribuye a la configuración de un futuro sostenible mediante innovaciones, desempeño de productos ambientales y producción ecológica con menor huella de CO2 y reciclaje más eficiente.

At ALUMINCO, one aspect stands above all others: **taking responsibility**. Under the heading "A planet to love", we are working the issue of sustainability along the entire value chain, making a significant contribution to shaping a sustainable future through innovations, environmental products' performance and green production with lower CO2 footprint and more efficient recycling.



¡Haga transformación real

La vista panorámica del mar Jónico y las verdes laderas que caen en mares azul verdoso es maravillosa, pero no es la única característica memorable que tiene este balcón de la casa.

¡Las barandilla clásicas son un elemento extremadamente dominante y una característica única de esta vista increíble!

The panoramic view over Ionian Sea and the green hillsides that

tumble down to blue-green seas is splendid, but it is not the only memorable feature that this balcony has to offer.

Selecting Classic Railings, have made this home a State-of-the-art!

¡HAGA UNA TRANSFORMACIÓN REAL

Nuestra colección clásica se basa en el saber hacer de más de 35 años. Desde edificios comerciales hasta diferentes estilos residenciales, cada solución es una obra de arte.

Descubra la gama completa de soluciones clásicas, las colecciones CLS, ALFLEX y PSATHA.

La durabilidad, la calidad y el estilo están garantizados. Opciones ilimitadas que crean una experiencia duradera para la vida al aire libre.

Our classic collection is built on the heritage and know-how of more than 35 years. From commercial buildings to diverse residential styles, each solution is a work of art.

Discover our complete line of classic solutions, the CLS, the ALFLEX and the PSATHA collections.

Durability, quality, and elegance are assured. Unlimited options that build lasting experiences for outdoor living spaces.

RENDIMIENTO DEL DISEÑO: LAS LÍNEAS CLS!

La estética es importante cuando se trata de barandillas clásicas. Pero no es solo la apariencia.

Las barandillas clásicas son una solución de vanguardia que combina altos estándares de seguridad.

Hecho de aluminio duradero, la estructura de las barandillas clásicas se basa en -especiales perfiles de aluminio, diseñadas que no requieren soldadura

Las columnas del sistema están disponibles en tres dimensiones, 40x40, 80x80 y 64x12, mientras que las bases de barandilla de alta calidad están diseñadas para una instalación superior.

Opcionalmente, las columnas se pueden instalar directamente en el hormigón sin una base en el medio.

El acabado de las barandillas clásicas con recubrimiento en polvo de alta durabilidad ofrece una alta protección y permanencia en el tiempo sin más mantenimiento especial.

Aesthetics matter when it comes to railings. But it is not just about looks.

Classic railings are a state-of-the-art solution combining high safety standards.

Made of durable aluminium, the railing structure is based on specially designed aluminium profiles, which do not require welding.

The posts are available in three dimensions, 40x40, 80x80 and 64x12, whereas high quality railing bases are designed for top installation. Optionally, the posts can be installed directly into the concrete without a base in between.

Finished in high durable powder coating, provide continuous years of virtually maintenance free railings.

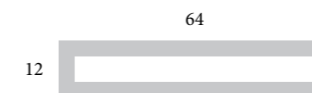
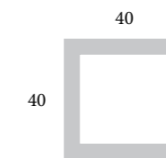
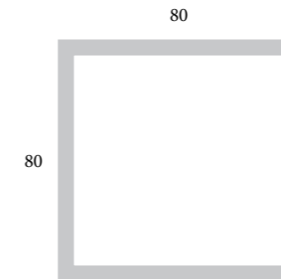



The CLS edition

¡Lo clásico se
encuentra con el
estilo

La colección CLS resume las tendencias de estilo de la era moderna: líneas elegantes y limpias, perpendiculares entre sí, forma cuadrada y equilibrada en el cuerpo y una superficie agradable.

18 modelos diferentes, disponibles en muchas configuraciones que satisfacen todos los deseos y todos los requisitos en términos de diseño y durabilidad, asegurando una solución de barandilla confiable en diferentes áreas de aplicación.

The CLS collection epitomizes styling trends of the day: elegant clean lines, vertical to each other, well balanced, square shape to the body and sleek lines.

18 different linear models, available in many configurations, meet any requirement from private homes to commercial buildings and heavy traffic areas.



34

35

24

Complejo de viviendas con CLS-E1 Bloque de viviendas con CLS-E1



CLS-C2



CLS-F2



CLS-D1



CLS-G1

The CLS *AVE*

¡Super privacidad en el área cubierta!

Usando el marco de la barandilla CLS, el relleno WAVE proporciona un alto nivel de privacidad y seguridad.

Using the framing of CLS railings, the Wave infills provide a maximum level of privacy and safety.



CLS A1

CLS B1

CLS C1



CLS A2

CLS B2

CLS C2



CLS D1

CLS E1

CLS F1



CLS D2

CLS E2

CLS F2



CLS G1

CLS H1

CLS WAVE 1



CLS G2

CLS H2

CLS WAVE 2

The ALFLEX *edition*

Piezas clásicas
emocionantes y
únicas!

La colección ALFLEX fue concebida para cerramiento de escaleras, balcones y terrazas. Con la flexibilidad como nuestro objetivo, la serie ofrece diseños diferentes y todos los conectores necesarios para asegurar cualquier tipo de instalación

Ideal tanto para viviendas nuevas o como remodeladoras.

The ALFLEX collection was conceived to cater for staircase enclosures apart from balconies and terraces.

As "flexible" is the key word, the series offers 17 different designs and all necessary connectors, to ensure any type of installation possible.

Ideal for new as well as remodelled homes.



Mansión moderna usando el diseño ALFLEX AGIOKLIMA Modern
mansion using ALFLEX AGIOKLIMA



65-41
AKANTHOS



85-31
LOUVRE



85-34
KAMARA



85-30
AGIOKLIMA



AGIOKLIMA



AKANTHOS



ASTERI A



EROTAS



SUN

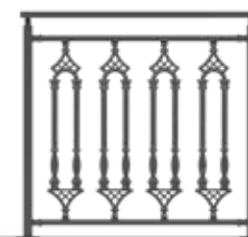

KAMARA

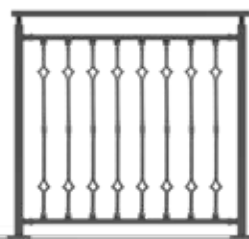

ASTERI B

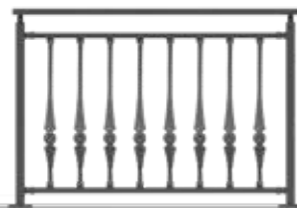

VENETIAN



LINEAR

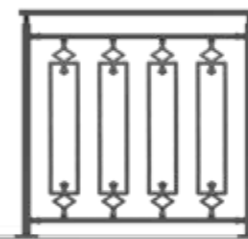

KOLONATO

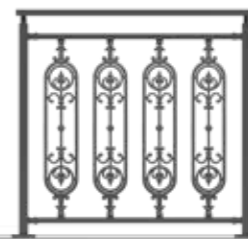

KORONA

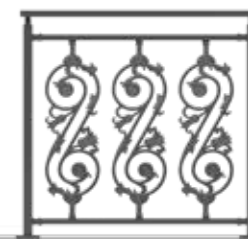

LOUVRE

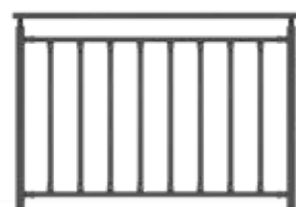

LINEAR 104

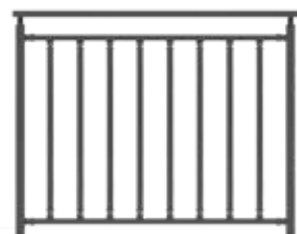

LINEAR 828



DILOS

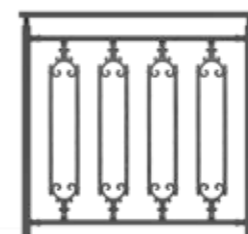

MAKRIYIANNI



MINOAN A

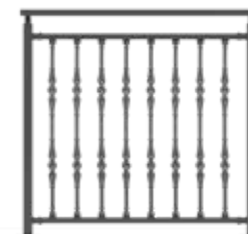

MINOAN B

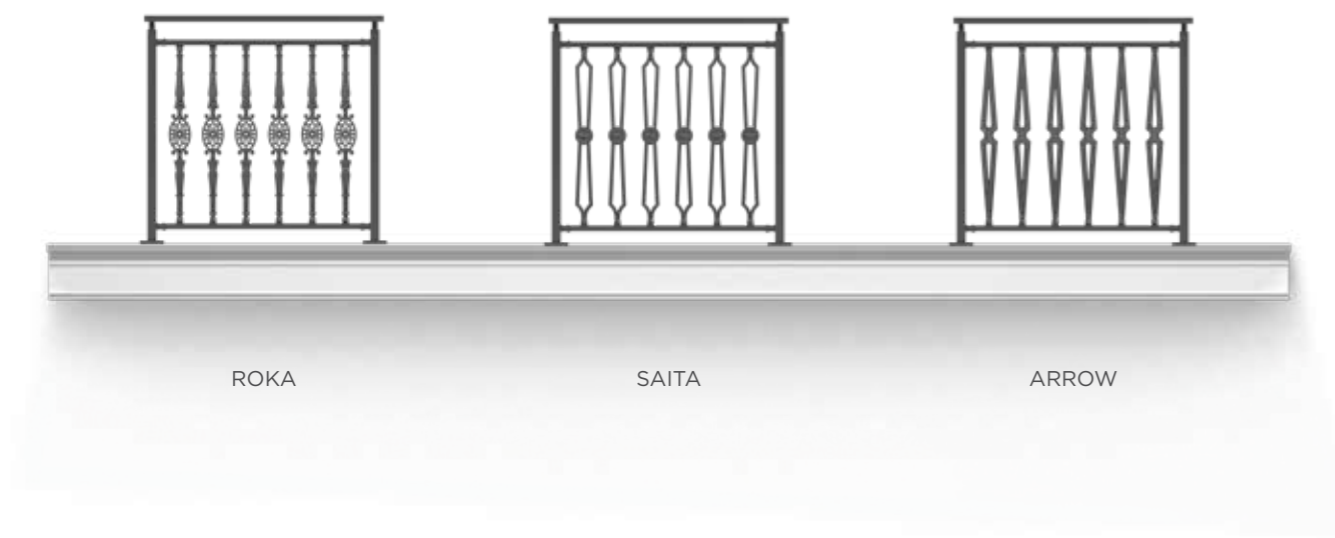

ROKA

SAITA

ARROW



TUSCANY



La colección PSATHA es una prueba real de que las barandillas son obras de arte.

Con la nueva expresión de la estética moderna floreciendo, nuestro enfoque de diseño de barandillas clásicas continúa por caminos frescos, pero también permanece en la línea de que lo clásico siempre tiene clase.

El cuerpo sólido de la barandilla destaca por las propiedades mecánicas y la resistencia interna del marco de aluminio. El interior está cubierto con representaciones de diseño que agregan carácter y estilo, a nuestras barandillas las cuales también clásicas ofrecen durabilidad frente a duras condiciones climáticas y resistencia para áreas de mucho tránsito.

The PSATHA collection is a real evidence that railings are artworks.

With the new expression of modern aesthetics flourished, our design approach on classic railings continues to fresh paths but also remains in line that classic is always classy.

The strong body of the railing underscored by the mechanical properties and inner strength of the aluminium frame whereas the infill is covered by design representations, adding character and style, and turning the railing into a work of art. A railing that stands like a sculpture.

This is the philosophy behind the design of PSATHA edition.

That enduring philosophy ensure that fine classic railings will always be built for beauty.

The PSATHA
edition

Clásico siempre tiene clase!



80-28



80-04
GOTHIC



80-10
ASTERI B



80-06
LINEAR 828



80-28

COLONIAN

ASTERI A



ATHENIAN

FLOWER POT

VIENNA



ASTERI B

GOTHIC

LINEAR 828



DORIC

ETHNIKIS

ERODIUS



KYKLADITIKO

MAKRIYIANNI

MINOAN A



KAMARA

KOLONATO

ELEPHANTS

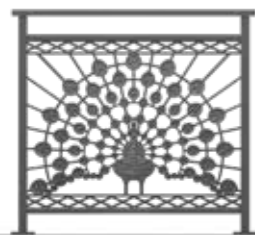

PEAFOWL

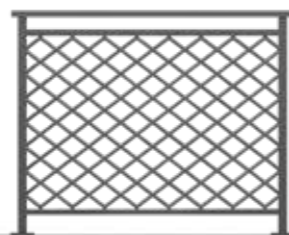

CHIASTI



PERIKOKLADA

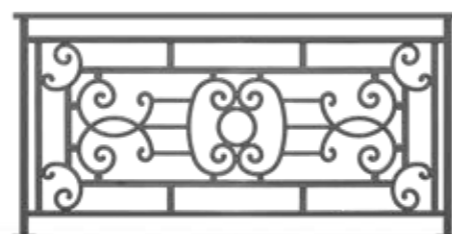

OLYMPIA

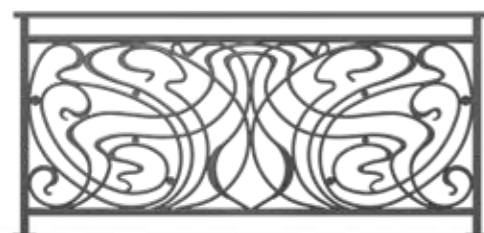

ZEFYROS

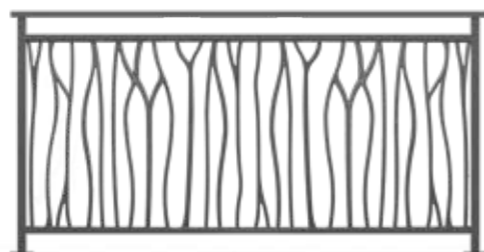

FOREST



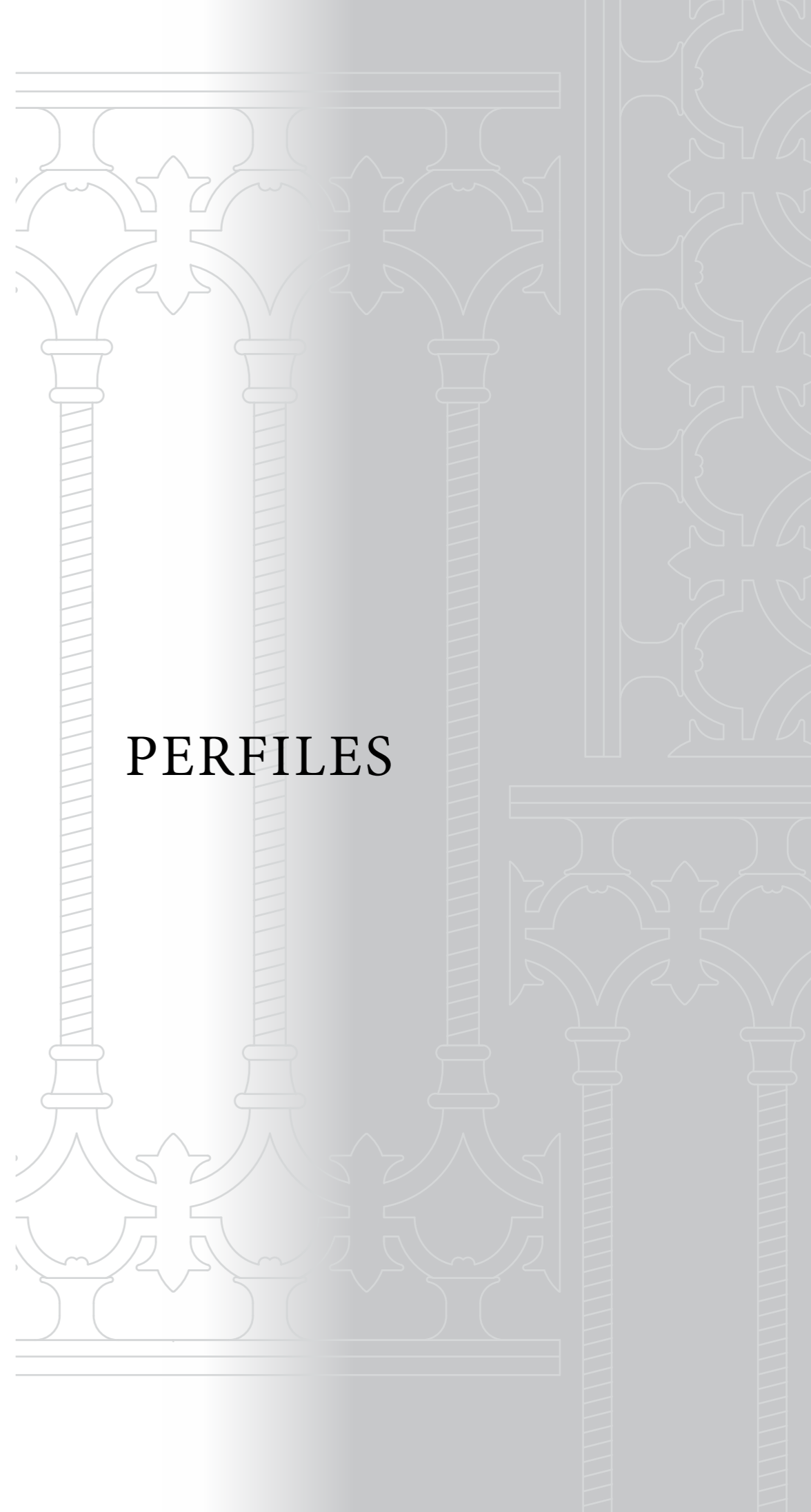

PERFILES

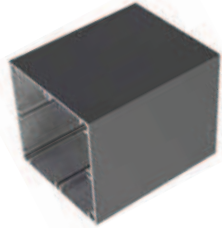
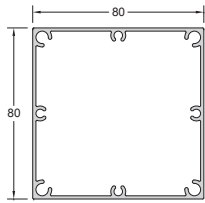

Código: **CLS-100** PESO/ WEIGHT:
1606 gr/m **COLUMNA 80x80**
COLUMN 80x80

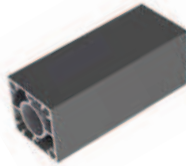
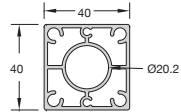

Código: **CLS-102**
PESO/ WEIGHT: 1245 gr/m
COLUMNA 40x40
COLUMN 40x40

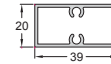

Código: **3200-601**
PESO/ WEIGHT: 502 gr/m
COLUMNA
MULLION PROFILE

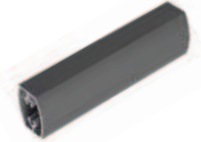
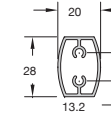

Código: **CLS-304** PESO /
WEIGHT: 389 gr/m
COLUMNA INTERIOR
INTERNAL COLUMN

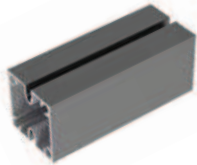
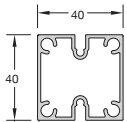

Código: **CLS-103** PESO/
WEIGHT: 945 gr/m
COLUMNA 40x40
COLUMN 40x40

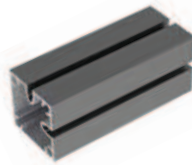
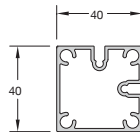

Código: **CLS-104** PESO/ WEIGHT: 945
gr/m **COLUMNA 40x40** **COLUMN**
40x40 CORNER

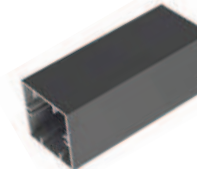
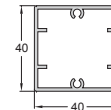

Código: **F50-106** PESO/
WEIGHT: 794 gr/m

PERFIL CUADRADO 40x40
SUPPORT COLUMN 40x40

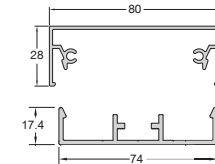

Código: **CLS-201** PESO/
WEIGHT: 757 gr/m
GUÍA
GUIDE

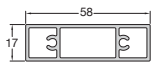

Código: **FSN-302**
PESO / WEIGHT: 781
gr/m
PERFIL 58x17
SQUARE 58x17

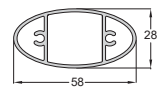

Código: **FSN-304** PESO/
WEIGHT: 804 gr/m
PERFIL OVALADO 58x28
PROFILE OVAL 58X28

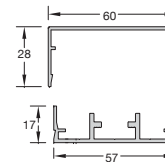

Código: **CLS-301**
PESO / WEIGHT:
588 gr/m **GUÍA**
GUIDE

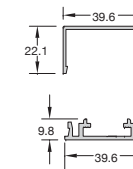

Código: **CLS-302**
PESO/ WEIGHT:
359 gr/m **GUÍA**
GUIDE

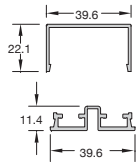

Código: **CLS-303**
 PESO / WEIGHT: 348 gr/m
GUÍA
 GUIDE

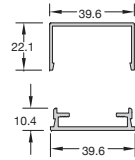

Código: **CLS-306**
 PESO / WEIGHT: 311 gr/
GUÍA
 GUIDE FOR FENCE
 RAILING

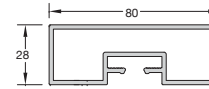

Código: **CLS-202**
 PESO / WEIGHT: 1360 gr/m
PASAMANOS 80x28
 HANDRAIL 80x28

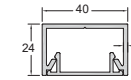

Código: **823**
 PESO / WEIGHT: 751 gr/m
RAÍL ESTUCHE PRESIÓN 24x40
 CLIPPED GUIDE 24x40

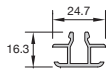

Código: **CLS-307**
 PESO / WEIGHT: 262 gr/m
GUÍA PARA AL-FLEX
 GUIDE FOR AL-FLEX

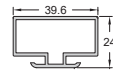

Código: **CLS-308**
 PESO / WEIGHT: 528 gr/m
GUÍA PARA AL-FLEX
 GUIDE FOR AL-FLEX

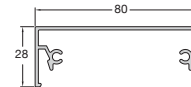

Código: **FSN-221** PESO/
 WEIGHT: 754 gr/m
TAPA PASAMANOS 80x28
 COVER FOR HANDRAIL 80x28

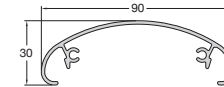
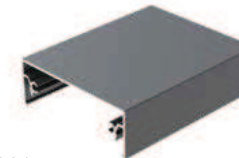

Código: **FSN-222**
 PESO / WEIGHT: 736 gr/m
TAPA PASAMANOS OVALADO 90x30
 COVER FOR HANDRAIL OVAL 90x30

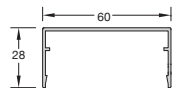

Código: **CLS-3K1**
 PESO / WEIGHT: 450 gr/m
TAPA PARA GUÍA CLS-301
 COVER FOR GUIDE CLS-301

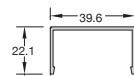
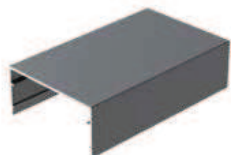

Código: **CLS-3K2**
 PESO / WEIGHT: 324 gr/m
TAPA PARA GUÍA CLS-302
 COVER FOR GUIDE CLS-302

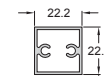
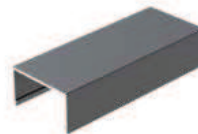

Código: **PAT05-003** PESO /
 WEIGHT: 369 gr/m
PERFIL 22x22 RECTANGULAR
 22x22

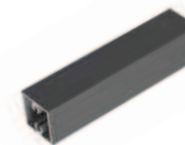

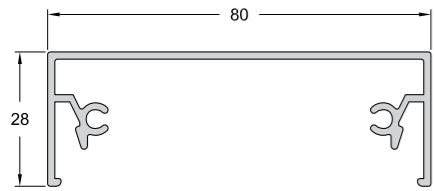

FSN-221

PESO / WEIGHT: 754 gr/m
TAPA DE LA CUBIERTA 80x28
COVER FOR HANDRAIL 80x28

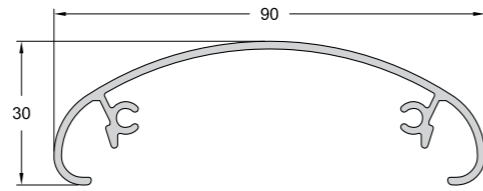

FSN-222

PESO / WEIGHT: 736 gr/m
FUNDA PARA PASAMANOS OVALADA 90x30
COVER FOR HANDRAIL OVAL 90x30

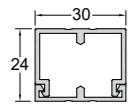

831

PESO / WEIGHT: 508 gr/m
TAPA RECTANGULAR 828
DRILLED GUIDE FOR PROFILE 828

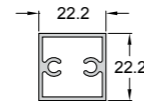

PAT05-003

PESO / WEIGHT: 369 gr/m
TAPA RECTANGULAR 22x22
RECTANGULAR 22x22

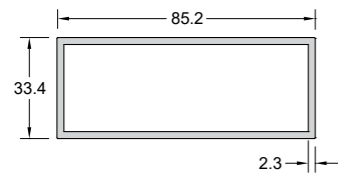

PAT59-392

PESO / WEIGHT: 1418 gr/m
TAPA RECTANGULAR 85.4x33.4x2
RECTANGULAR 85.4x33.4x2

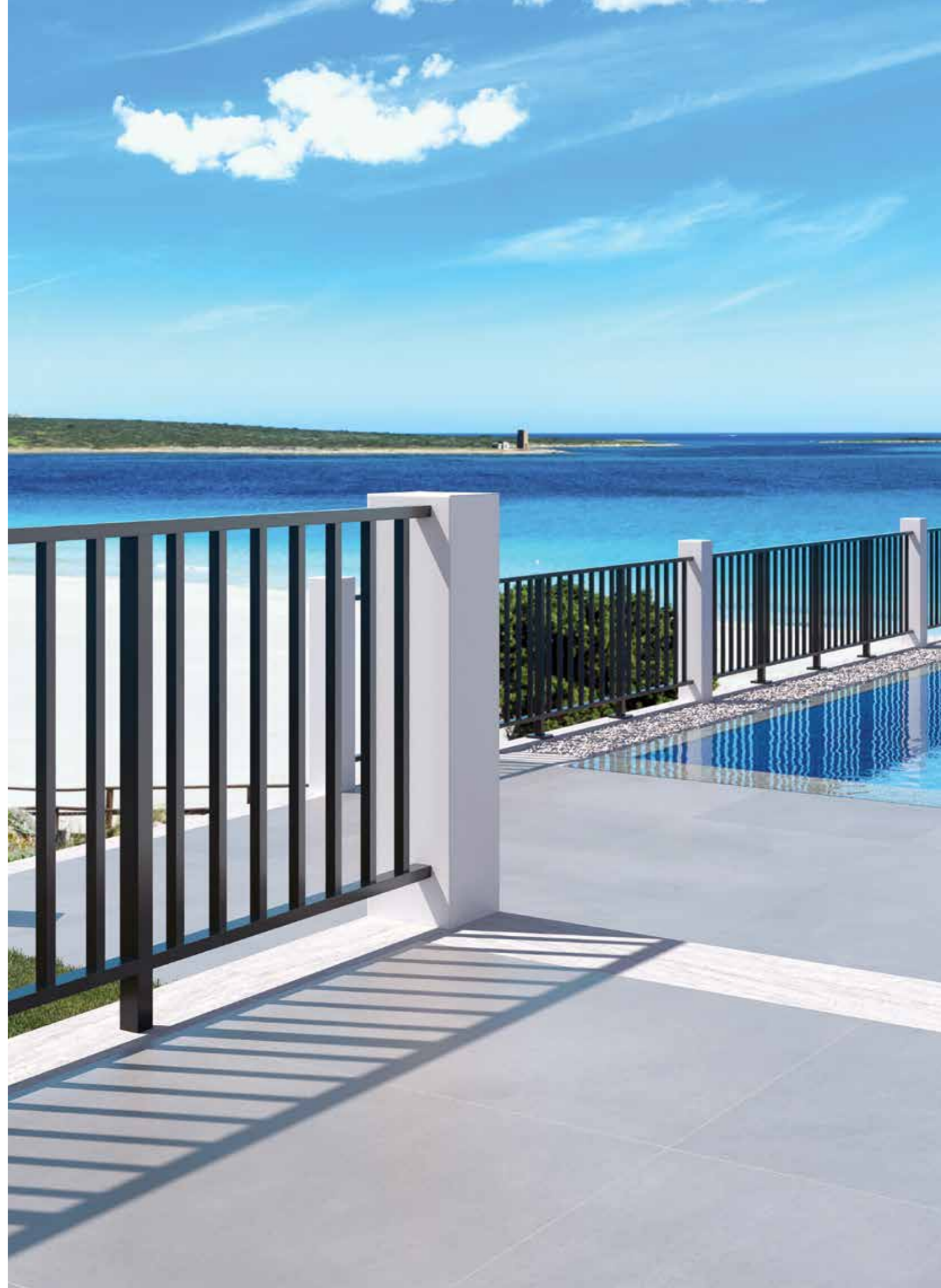



ACCESORIOS



4113
SUELO DE SOPORTE PARA COLUMNA 93
SUPPORT FOOT FOR COLUMN 93



4188
SOPORTE DE COLUMNA PARA PISO INTERIOR F50-102
INFLOOR SUPPORT FOR F50-102 COLUMN

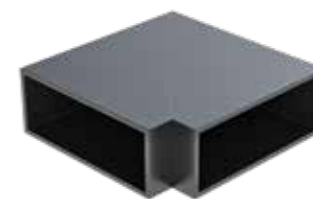

4273
CONECTOR DE ÁNGULO 90° CLS-201/FSN-221
CORNER CONNECTOR FOR CLS-201/FSN-221



4274
ALFOMBRA EXTERIOR
EXTERNAL PSATHA SUPPORT



4261
CONECTOR PASAMANOS HORIZONTAL
HANDRAIL CONNECTOR HORIZONTAL



4270
CONECTOR CLS-201/301/302/305
CONNECTOR FOR CLS-201/301/302/305



4275
ENLACE DE GUÍA INTERNA CLS-302 EYΘEIA
CONNECTOR FOR GUIDE CLS-302



4276
ENLACE DE GUÍA INTERNA CLS-306 EYΘEIA
CONNECTOR FOR GUIDE CLS-306



4271
ENLACE DE GUÍA INTERNA CLS-303
CONNECTOR FOR GUIDE CLS-303



4272
ENLACE DE GUÍA INTERNA CLS-306
CONNECTOR FOR GUIDE CLS-306



4278
ENLACE DE GUÍA INTERNA CLS-303 EYΘEIA
CONNECTOR FOR GUIDE CLS-303



4282
COLUMNA DE SOPORTE PARA PARED (ESQUINA) CLS-102 MB
WALL SUPPORT FOR COLUMN CLS-102

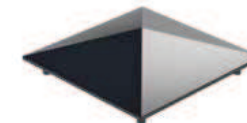
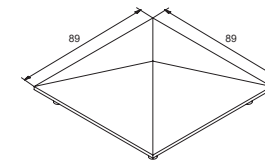
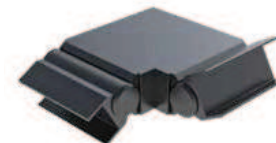
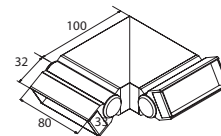
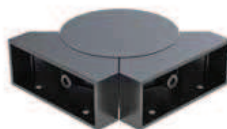
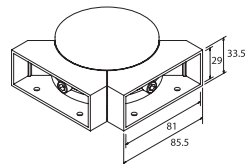
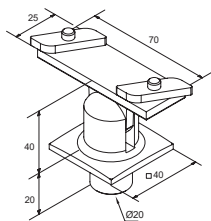

Código: **4345**
UNIÓN COLUMNA CLS-102 CON PASAMANOS F50-201
CONNECTOR FOR CLS-102 COLUMN WITH
F50-201 HANDRAIL

Código: **4375**
CONECTOR ESQUINERO AJUSTABLE PARA PASAMANOS
CLS- 201 / FSN-221 ADJUSTABLE CORNER CONNECTOR
FOR HANDRAIL CLS- 201/FSN-221

Código: **4384**
CONECTOR ESQUINA REGULABLE 90 ° PARA
PASAMANOS CLS-202 (ESCALERAS)
ADJUSTABLE CORNER CONNECTOR
90° FOR CLS-202 HANDRAIL (STAIRS)

Código: **4485**
TAPA PARA COLUMNA CLS-100
COVER FOR COLUMN CLS-100

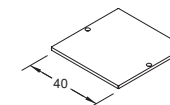
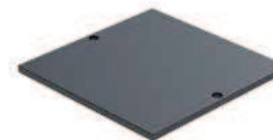
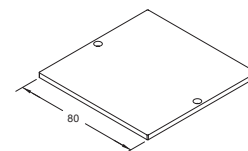
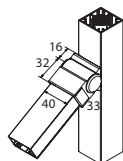
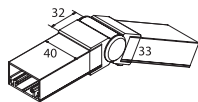

Code: **4376**
CONECTOR DE PASAMANOS PARA CLS-3K2 /
302 HANDRAIL CONNECTOR FOR
CLS-3K2/302

Código: **4377**
CONECTOR PARA GUIA CLS-3K2 CON COLUMNA
CLS-102 CONNECTOR FOR GUIDE CLS-3K2
WITH COLUMN CLS-102

Código: **4486**
TAPA PARA COLUMNA CLS-100 (80x80)
END CAP FOR COLUMN CLS-100
(80x80) FLAT

Código: **4487**
TAPA PARA COLUMNA CLS-102 (40x40)
END CAP FOR COLUMN CLS-102 (40x40)
FLAT

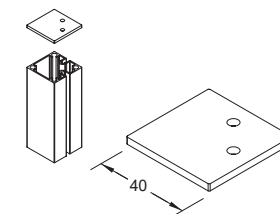
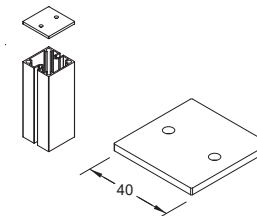
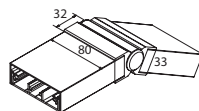
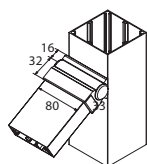

Code: **4378**
CONECTOR PARA PASAMANOS FSN-221 CON
COLUMNA CLS-100 CONNECTOR FOR HANDRAIL
FSN-221 WITH COLUMN CLS-100

Código: **4379**
CONECTOR AJUSTABLE PARA
PASAMANOS CLS-202 ADJUSTABLE
CONNECTOR FOR HANDRAIL
CLS-202

Código: **4489**
TAPA PARA COLUMNA CLS-103
(40x40)
END CAP FOR COLUMN CLS-103
(40x40) FLAT

Código: **4490**
TAPA PARA COLUMNA CLS-104
(40x40)
END CAP FOR COLUMN CLS-104
(40x40) FLAT

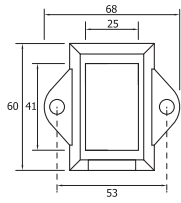

Code: **4504**
TAPA GUÍA 823 (24 X 40)
 WALL COVER FOR GUIDE
 823 (24x40)

Code: **4507**
TAPA COLUMNA 40 X 40
 WALL COVER FOR
 COLUMN 40x40

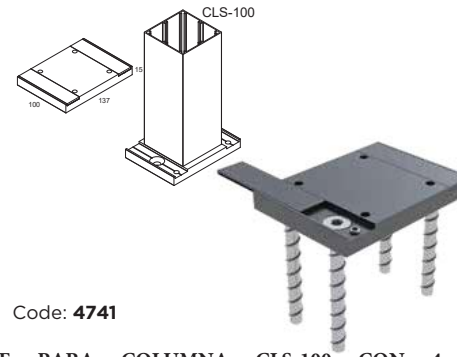

Code: **4741**
PIE PARA COLUMNA CLS-100 CON 4
TORNILLOS DE HORMIGÓN SUPPORT FOOT
FOR COLUMN CLS-100 WITH 4
CONCRETE SCREWS

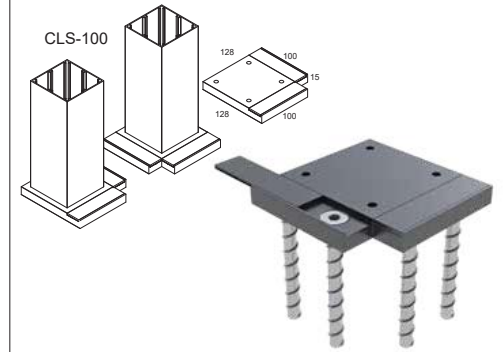

Code: **4742**
PIE PARA COLUMNA CLS-100 CON 4 TORNILLOS
DE HORMIGÓN SUPPORT FOOT FOR COLUMN
CLS-100 WITH 4 CONCRETE SCREWS

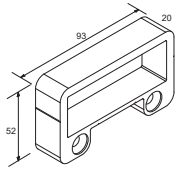

Code: **4525**
TAPA PARA PASAMANOS
CLS-202/201 WALLCOVER FOR
HANDRAIL CLS-202/201

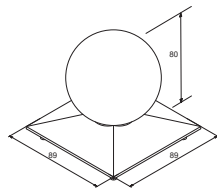

Code: **4621**
TAPA PARA COLUMNA CLS 100
COVER WITH THYRSUS FOR
COLUMN CLS-100

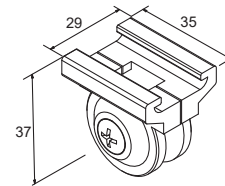

Code: **22**
CABEZA AL-FLEX PARA GUÍA
AL-FLEX HEAD
ATTACHMENT FOR GUIDE

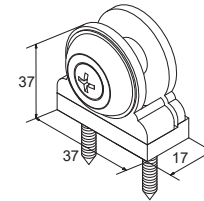

Code: **24**
CABEZA AL-FLEX
AL-FLEX HEAD
ATTACHMENT

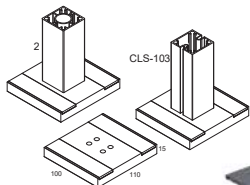

Code: **4723**
PIE PARA COLUMNA CLS-102
SUPPORT FOOT FOR
COLUMN CLS-102

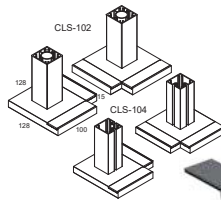

Code: **4724**
PIE PARA COLUMNA CLS-102
SUPPORT FOOT FOR COLUMN
CLS-102



COMBINACIONES





Code: **828**
 PESO / WEIGHT: 313 gr/m
 COLUMNA 28x20
 COLUMN 28x20



Code: **831**
 PESO / WEIGHT: 508 gr/m
 GUÍA PERFORADA PARA PERFILES 828 DRILLED
 GUIDE FOR PROFILE 828

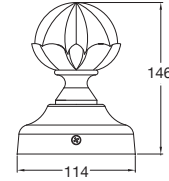

Code: **4613**
 TAPA CON PILAR PARA COLUMNA
 100X100 COVER WITH THIRSUS FOR COLUMN
 100X100

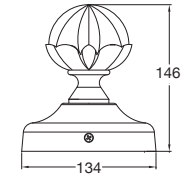

Code: **4614**
 TAPA CON PUERTA PARA COLUMNA 120X120
 120X120 COVER WITH THIRSUS FOR COLUMN 120X120



Code: **239**
 FLECHAS DECORATIVAS
 (77x22) SPIKE FOR FENCE (77x22)

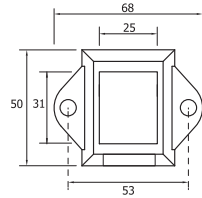

Code: **4503**
 TAPA GUIA WALL COVER FOR
 GUIDE

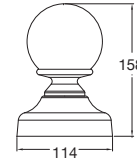

Code: **4616**
 TAPA CON PUERTA REDONDA PARA COLUMNA
 100X100 COVER WITH GLOBAL THIRSUS FOR COLUMN 100X100

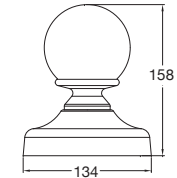

Code: **4617**
 TAPA CON PUERTA PARA COLUMNA 120x120
 COVER WITH GLOBAL THIRSUS FOR COLUMN 120X120



Code: **240**
 FLECHAS DECORATIVAS 828
 SPIKE FOR FENCE FOR PROFILE 828



Code: **121**
 CABEZAL PARA PERFIL 104
 HEAD ATTACHMENT FOR PROFILE 104



Code: **104**
 PESO / WEIGHT: 197 gr/m
 COLUMNA AL-FLEX 22x17
 COLUMN FOR AL-FLEX 22x17

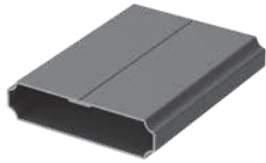
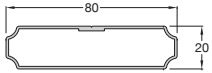

Code: **822**

PESO/ WEIGHT: 629 gr/m

PERFIL DE LA VALLA 80x20

PROFILE FOR FENCE 80x20

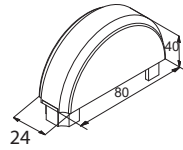

Code: **4410**

TAPA DEL PERFIL 822

END CAP FOR PROFILE 822



Code: **65**

CAPITEL DECORATIVO

CAPITAL OF PILLAR



Code: **69**

FIN DE COLUMNA (165x155)

COVER FOR COLUMN (165x155)



Code: **178**

DECORACION SUPERIOR CANCELA 78cm

KLARA 78cm



Code: **179** DECORACIÓN SUPERIOR CANCELA 95cm

PERIKOKLADA 95cm



Code: **66**

BASE DE LA COLUMNA

(30x16cm) BASE FOR COLUMN (30x16cm)



Code: **180**

DECORACIÓN SUPERIOR CANCELA 54cm

KLARA 54cm



Code: **217**

DECORACIÓN SUPERIOR CANCELA

82cm KLARA
DOUBLE 82cm

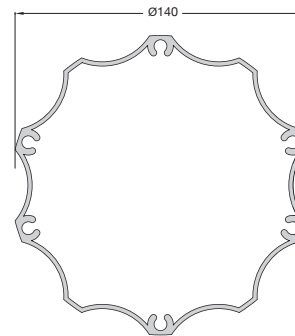

Code: **67**

PESO / WEIGHT: 3153 gr/

m COLUMNA 140x140

COLUMN 140x140

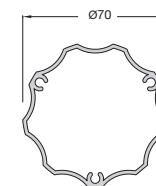

Code: **70**

PESO/ WEIGHT: 1229 gr/m

COLUMNA 70x70

COLUMN 70x70



WWW.ALUMINCO.ES

TELF: 916926850

info@aluminco-panel.es

C/ Arroyo culebro s/n nave 5
Pol.Industrial Las Arenas
28320 Pinto, Madrid
(España)